

Evaporator Outlet Line

Material

Item	Specification
Motorcraft® PAG Refrigerant Compressor Oil YN-12-D	WSH-M1C231-B

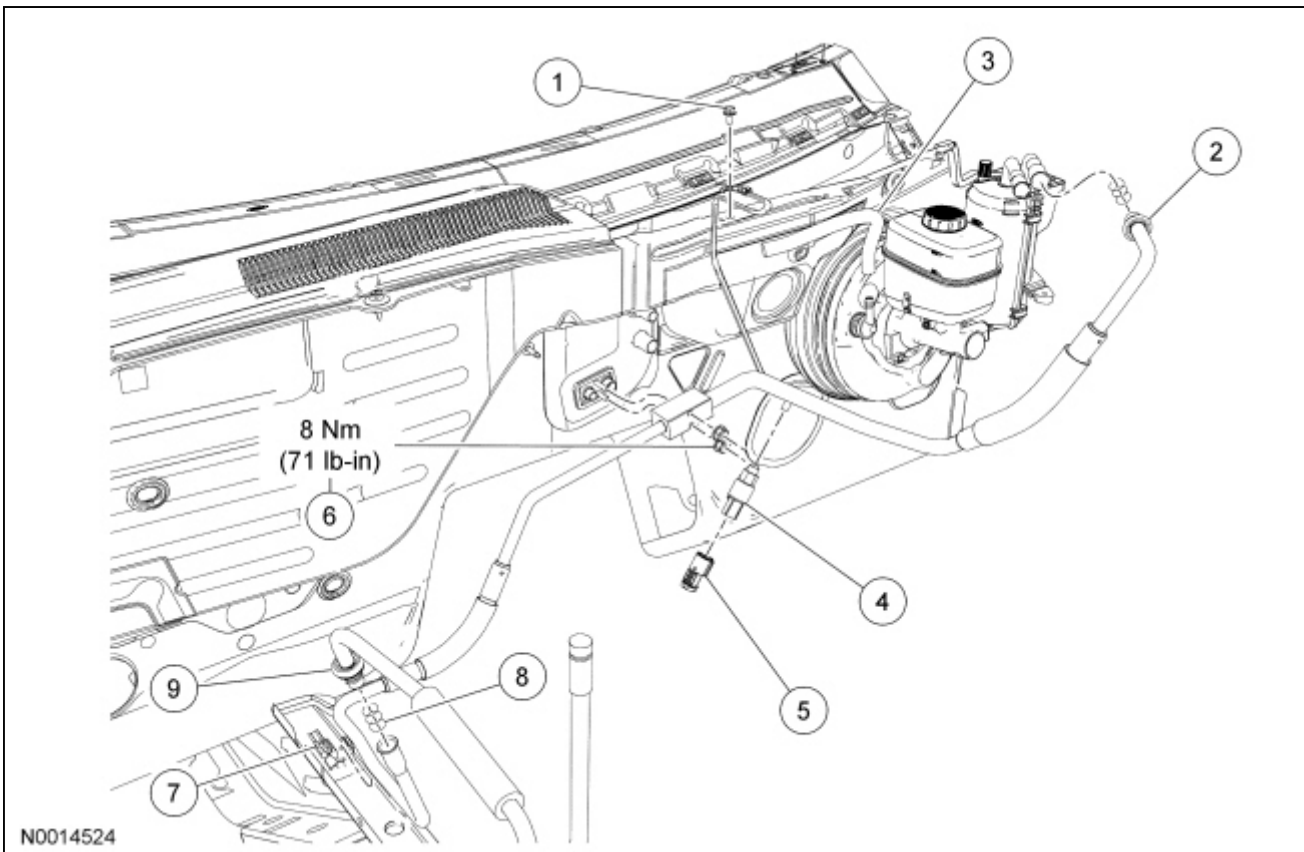

Item	Part Number	Description
1	54042A06	Body ground strap bolt
2	—	Suction accumulator inlet fitting (part of 19835)
3	9C482	Brake booster vacuum hose
4	19E561	A/C cycling switch
5	—	A/C cycling switch electrical connector (part of 12B637)
6	W701838	Evaporator fitting nut (2 required)
7	9F274	Evaporator inlet line clip
8	19E889	O-ring seal (8 required)
9	—	Evaporator inlet line fitting (part of 19835)

Removal and Installation

All vehicles

1. Recover the refrigerant. For additional information, refer to [Section 412-00](#).

5.4L (4V) vehicles

2. Drain the engine cooling system. For additional information, refer to [Section 303-03A](#).
3. Remove the brake booster. For additional information, refer to [Section 206-07](#).
4. Disconnect the 2 heater hose connections at the rear of the RH cylinder head and position the heater hoses aside.

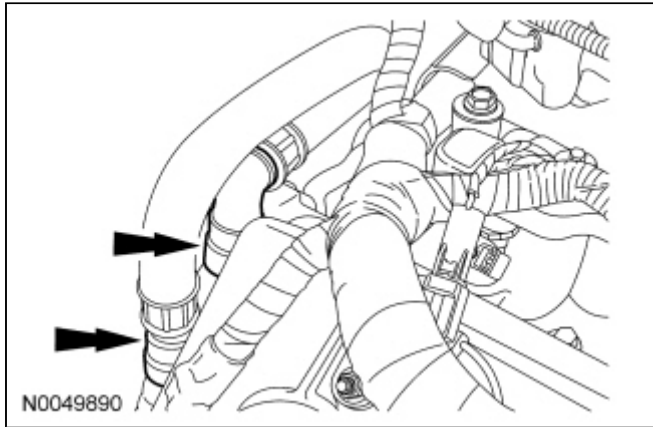

5. Remove the EGR system module tube. For additional information, refer to [Section 303-08](#).

4.0L and 4.6L vehicles

6. Remove the LH cowl vent screen. For additional information, refer to [Section 501-02](#).
7. Remove the body ground strap bolt.
8. Disconnect the brake booster vacuum hose at the brake booster.

All vehicles

9. Disconnect the A/C cycling switch electrical connector and detach the wire harness from the evaporator outlet line.
10. Remove the A/C cycling switch.
11. Disconnect the evaporator inlet line fitting.
 - Discard the O-ring seals.
12. Detach the evaporator inlet line clip.
13. Disconnect the suction accumulator inlet fitting.
 - Discard the O-ring seals.
14. Remove the 2 evaporator fitting nuts and disconnect the fitting.
 - Discard the O-ring seals.
 - To install, tighten to 8 Nm (71 lb-in).
15. Remove the evaporator tube bracket.
 1. Rotate the evaporator tube bracket downward.
 2. Remove the evaporator tube bracket.

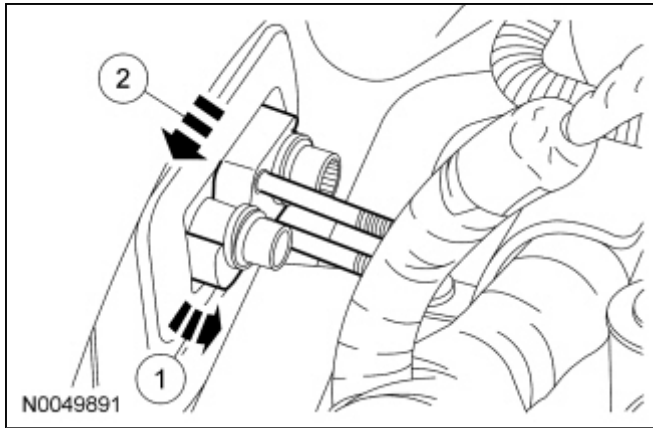

16. Remove the evaporator core manifold and tube assembly.
17. To install, reverse the removal procedure.
 - Install new O-ring seals.
 - Lubricate the refrigerant system with the correct amount of clean PAG oil. For additional information, refer to [Section 412-00](#).

5.4L (4V) vehicles

18. Fill the engine cooling system. For additional information, refer to [Section 303-03A](#).

All vehicles

19. Evacuate, leak test and charge the refrigerant system. For additional information, refer to [Section 412-00](#).
-